HELIO Optoelectronics Corp.

Helixeon - Color Series



Helixeon, a solid-state lighting device, provides

high luminous flux output with high efficiency. Helixeon is encapsulated in silicone by molding technology. Also, Helixeon is capable of standard lead free solder reflow process. The standard color product line includes red, green, blue amber, and etc.

Features

- | High luminous flux output
- | Long life operation
- | Instant response
- | RoHS certification
- | Superior ESD protection

Application

- | Decoration lighting
- | Architectural lighting
- | Stage lighting
- | General lighting

HELIO Optoelectronics Corp.

Product Nomenclature

HM **HP** - **E** **3** **L** **R**
 X1 X2 X3 X4 X5 X6

X1		X2		X3		X4	
Item		Mode		Heat sink		Power	
Code	Type	Code	Type	Code	Type	Code	Type
HM	Molding	HP	High power	E	Emitter	3	3W

X5		X6	
Pattern		Color	
Code	Type	Code	Type
L	Lambertian	R	Red
		G	Green
		B	Blue
		A	Amber

Circuit Diagram of Helixeon- Emitter

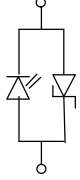
Color	Part number	Circuit diagram
Red	HMHP-E3LR	
Green	HMHP-E3LG	
Blue	HMHP-E3LB	
Amber	HMHP-E3LA	

The information contained herein is the exclusive property of HELIO and shall not be distributed reproduced, or disclosed in whole or in part without prior written permission of HELIO.

HELIO Optoelectronics Corp.

Package Dimensions

Lead Form

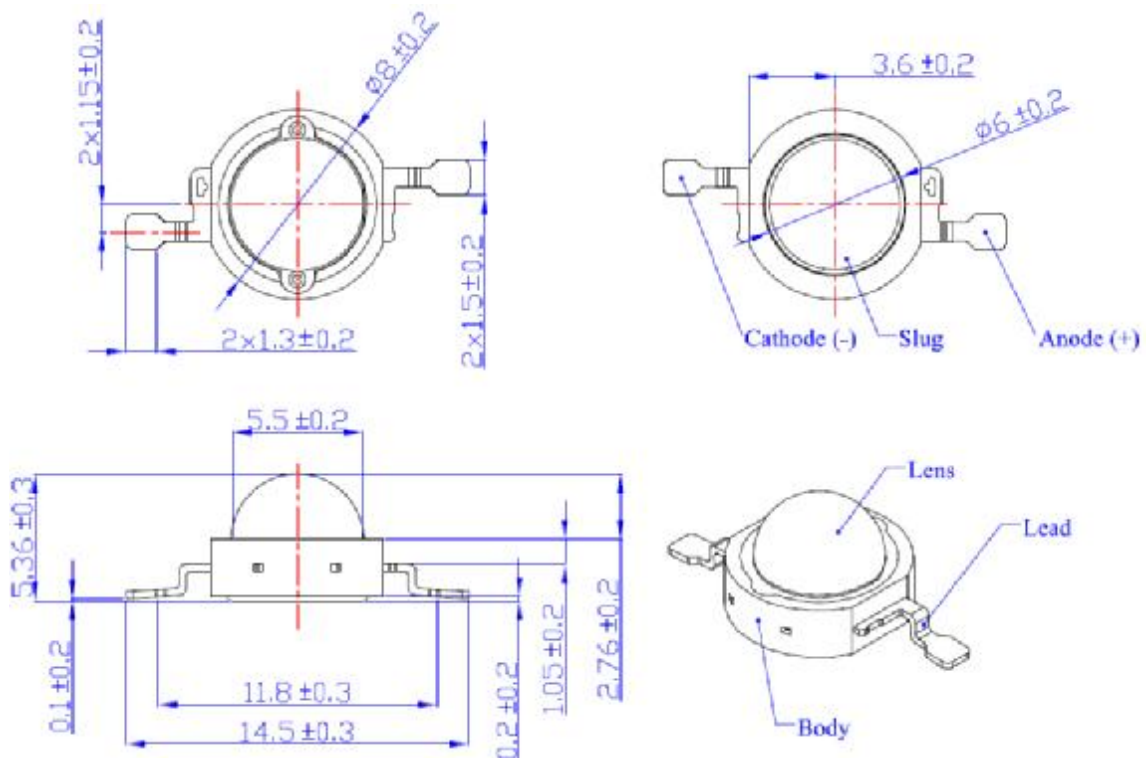

Note:

1. The anode side of the device is denoted by a hole in the lead frame.
2. Electrical insulation between the case and the board is required. The slug of the device is no electrically neutral.
3. Drawings are not to scale.
4. All dimensions are all in millimeter.
5. All dimensions without tolerance are for reference only.
6. Specifications are subject to change without notice.

The information contained herein is the exclusive property of HELIO and shall not be distributed reproduced, or disclosed in whole or in part without prior written permission of HELIO.

HELIO Optoelectronics Corp.

Package Dimensions

MCPCB Form

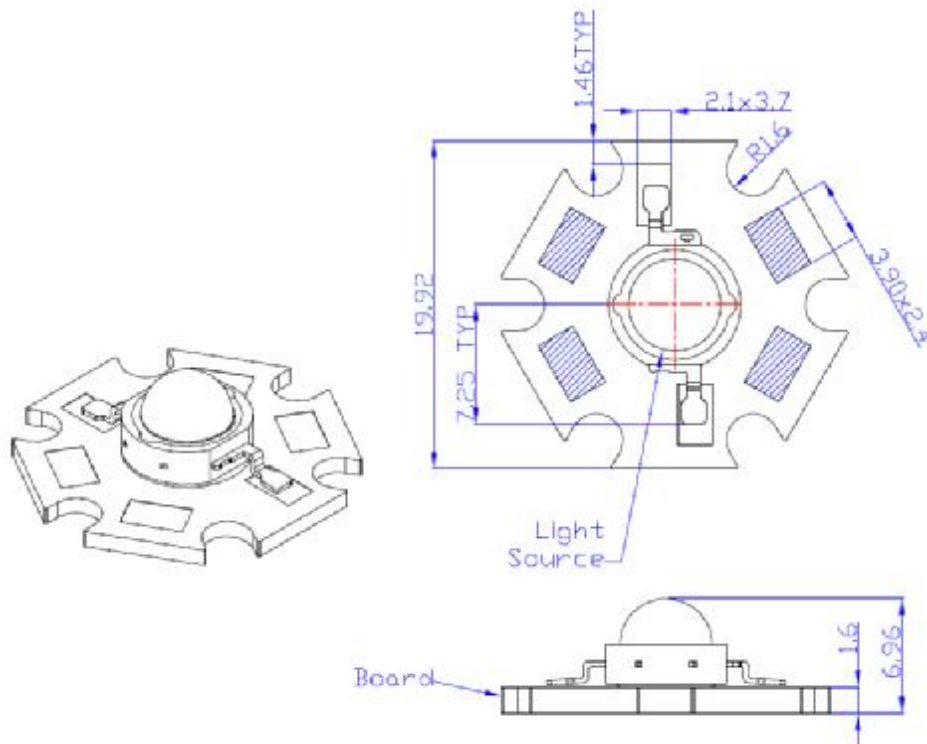

Note:

1. Slots in aluminum-core PCB for M3 mounting screw.
2. Electrical interconnection pads labeled on the aluminum-PCB with “+” and “-“ to denote positive and negative, respectively.
3. Drawings are not to scale.
4. All dimensions are in millimeters.

The information contained herein is the exclusive property of HELIO and shall not be distributed reproduced, or disclosed in whole or in part without prior written permission of HELIO.

*HELIO Optoelectronics Corp.*

Characteristics for Helixeon Color emitter

HMHP-E3LR

Characteristics at $I_F = 700\text{mA}$ ($T_a = 25^\circ\text{C}$):

Parameter	Symbol	Value			Unit
		Min	Typical	Max	
Luminous flux ⁽¹⁾	Φ_v ⁽²⁾	59.5	75	--	lm
Dominant wavelength ⁽³⁾	Wd	610	--	630	nm
View angle	$2\Theta_{1/2}$	--	150	--	degree
Forward voltage ⁽⁴⁾	V_F	2.0	--	3.0	V
Power dissipation	P_D	1.4	--	2.1	W
Junction temperature	T_J	--	--	120	Deg.
Operation temperature	T_{OP}	-40~+105			$^\circ\text{C}$
Storage temperature	T_{ST}	-40~+120			$^\circ\text{C}$
ESD sensitivity		>8000 HBM			V

Bin code

Luminous flux (lm)	Rank (BIN)	Wavelength (nm)	Rank (BIN)
39.8	R0	610	A0
51.7	S0	620	B0
67.2	T0	630	C0
87.4	U0		

Note:

1. The typical luminous flux of Helixeon will be upgraded per season.
2. Φ_v , minimum luminous flux performance guaranteed within published operating conditions. HELIO maintains a tolerance of $\pm 10\%$ luminous flux measurements.
3. Dominant wavelength is derived from the CIE1931 chromaticity diagram and represents the perceived color. The tester tolerance of dominant wavelength is $\pm 1\text{nm}$.
4. HELIO maintains a tolerance of $\pm 0.06\text{V}$ on forward voltage measurements.

The information contained herein is the exclusive property of HELIO and shall not be distributed reproduced, or disclosed in whole or in part without prior written permission of HELIO.

*HELIO Optoelectronics Corp.*

Characteristics for Helixeon Color emitter

HMHP-E3LG

Characteristics at $I_F = 700\text{mA}$ ($T_a = 25^\circ\text{C}$):

Parameter	Symbol	Value			Unit
		Min	Typical	Max	
Luminous flux ⁽¹⁾	Φ_v ⁽²⁾	113.6	145	--	lm
Dominant wavelength ⁽³⁾	λ_d	515	--	535	nm
View angle	$2\Theta_{1/2}$	--	150	--	degree
Forward voltage ⁽⁴⁾	V_F	3.0	--	4.0	V
Power dissipation	P_D	2.1	--	2.8	W
Junction temperature	T_J	--	--	120	Deg.
Operation temperature	T_{OP}	-40~+105			$^\circ\text{C}$
Storage temperature	T_{ST}	-40~+120			$^\circ\text{C}$
ESD sensitivity		>8000 HBM			V

Bin code

Luminous flux (lm)	Rank (BIN)	Wavelength (nm)	Rank (BIN)
87.4	U0	510	A0
113.6	V0	515	B0
147.7	W0	520	C0
192.0	X0	525	D0
		530	E0

Note:

1. The typical luminous flux of Helixeon will be upgraded per season.
2. Φ_v , minimum luminous flux performance guaranteed within published operating conditions. HELIO maintains a tolerance of $\pm 10\%$ luminous flux measurements.
3. Dominant wavelength is derived from the CIE1931 chromaticity diagram and represents the perceived color. The tester tolerance of dominant wavelength is $\pm 1\text{nm}$.
4. HELIO maintains a tolerance of $\pm 0.06\text{V}$ on forward voltage measurements.

The information contained herein is the exclusive property of HELIO and shall not be distributed reproduced, or disclosed in whole or in part without prior written permission of HELIO.

*HELIO Optoelectronics Corp.*

Characteristics for Helixeon Color emitter

HMHP-E3LB

Characteristics at $I_F = 700\text{mA}$ ($T_a = 25^\circ\text{C}$):

Parameter	Symbol	Value			Unit
		Min	Typical	Max	
Luminous flux ⁽¹⁾	Φ_v ⁽²⁾	30.6	35	--	lm
Dominant wavelength ⁽³⁾	λ_d	460	--	475	nm
View angle	$2\Theta_{1/2}$	--	150	--	degree
Forward voltage ⁽⁴⁾	V_F	3.0	--	4.0	V
Power dissipation	P_D	2.1	--	2.8	W
Junction temperature	T_J	--	--	120	Deg.
Operation temperature	T_{OP}	-40~+105			$^\circ\text{C}$
Storage temperature	T_{ST}	-40~+120			$^\circ\text{C}$
ESD sensitivity		>8000 HBM			V

Bin code

Luminous flux (lm)	Rank (BIN)	Wavelength (nm)	Rank (BIN)
23.5	P0	460	E0
30.6	Q0	465	F0
39.8	R0	470	G0
51.7	S0		

Note:

1. The typical luminous flux of Helixeon will be upgraded per season.
2. Φ_v , minimum luminous flux performance guaranteed within published operating conditions. HELIO maintains a tolerance of $\pm 10\%$ luminous flux measurements.
3. Dominant wavelength is derived from the CIE1931 chromaticity diagram and represents the perceived color. The tester tolerance of dominant wavelength is $\pm 1\text{nm}$.
4. HELIO maintains a tolerance of $\pm 0.06\text{V}$ on forward voltage measurements.

The information contained herein is the exclusive property of HELIO and shall not be distributed reproduced, or disclosed in whole or in part without prior written permission of HELIO.

*HELIO Optoelectronics Corp.*

Characteristics for Helixeon Color emitter

HMHP-E3LA

Characteristics at $I_F = 700\text{mA}$ ($T_a = 25^\circ\text{C}$):

Parameter	Symbol	Value			Unit
		Min	Typical	Max	
Luminous flux ⁽¹⁾	Φ_v ⁽²⁾	51.7	60	--	lm
Dominant wavelength ⁽³⁾	λ_d	585	--	595	nm
View angle	$2\Theta_{1/2}$	--	150	--	degree
Forward voltage ⁽⁴⁾	V_F	2.0	--	3.0	V
Power dissipation	P_D	1.4	--	2.1	W
Junction temperature	T_J	--	--	120	Deg.
Operation temperature	T_{OP}	-40~+105			$^\circ\text{C}$
Storage temperature	T_{ST}	-40~+120			$^\circ\text{C}$
ESD sensitivity		>8000 HBM			V

Bin code

Luminous flux (lm)	Rank (BIN)	Wavelength (nm)	Rank (BIN)
39.8	R0	585	A0
51.7	S0	587.5	B0
67.2	T0	590	C0
87.4	U0	592.5	D0

Note:

1. The typical luminous flux of Helixeon will be upgraded per season.
2. Φ_v , minimum luminous flux performance guaranteed within published operating conditions. HELIO maintains a tolerance of $\pm 10\%$ luminous flux measurements.
3. Dominant wavelength is derived from the CIE1931 chromaticity diagram and represents the perceived color. The tester tolerance of dominant wavelength is $\pm 1\text{nm}$.
4. HELIO maintains a tolerance of $\pm 0.06\text{V}$ on forward voltage measurements.

The information contained herein is the exclusive property of HELIO and shall not be distributed reproduced, or disclosed in whole or in part without prior written permission of HELIO.



HELIO Optoelectronics Corp.

Optical characteristics

Emission spectrum

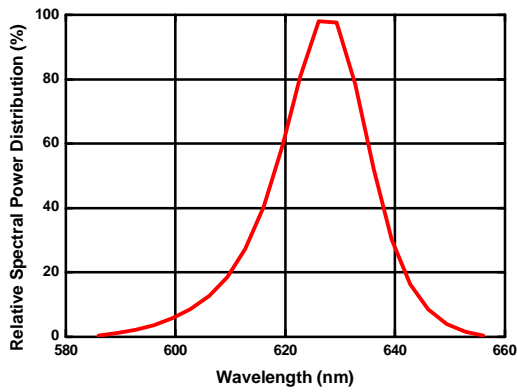

Red

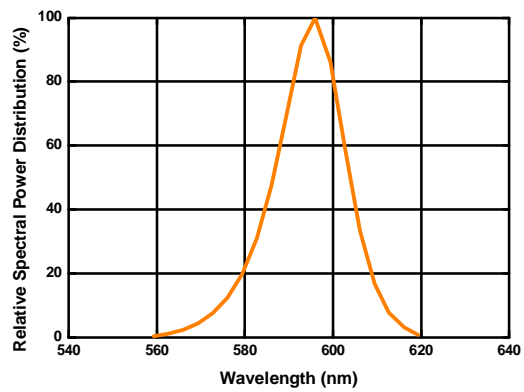

Amber

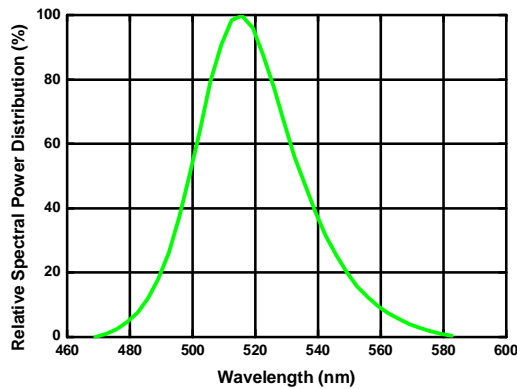

Green

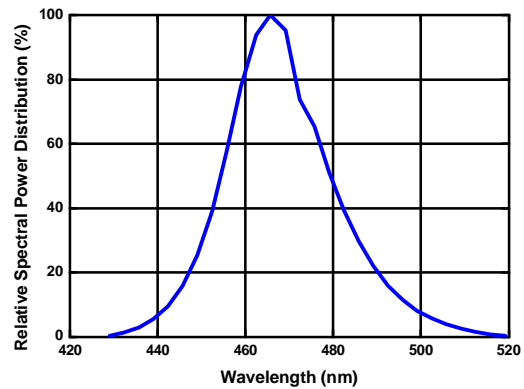

Blue

The information contained herein is the exclusive property of HELIO and shall not be distributed reproduced, or disclosed in whole or in part without prior written permission of HELIO.



HELIO Optoelectronics Corp.

Radiation Pattern

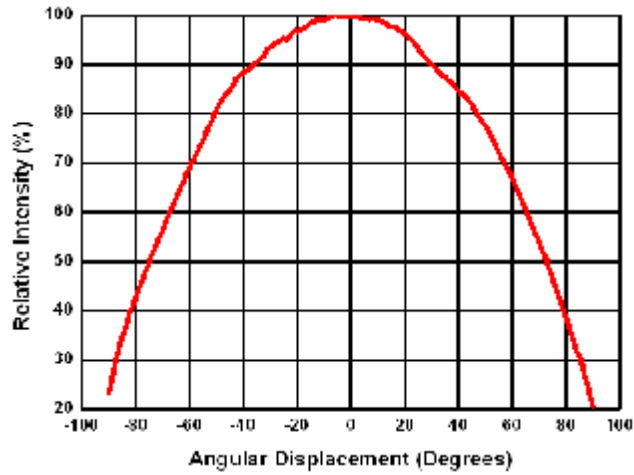

Red, Amber

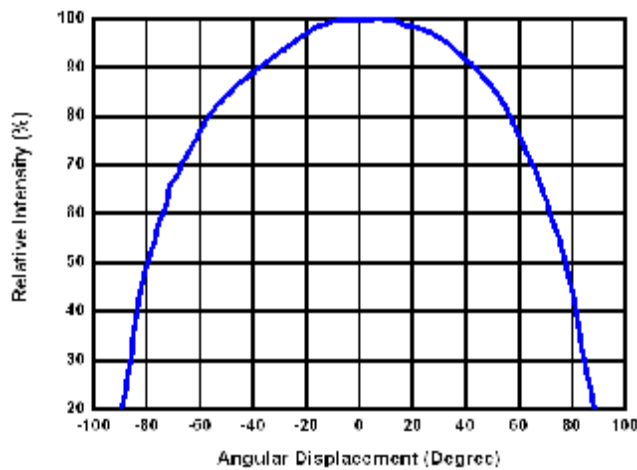

Green, Blue

The information contained herein is the exclusive property of HELIO and shall not be distributed reproduced, or disclosed in whole or in part without prior written permission of HELIO.



HELIO Optoelectronics Corp.

Electrical characteristics

Typical Forward Current Characteristics

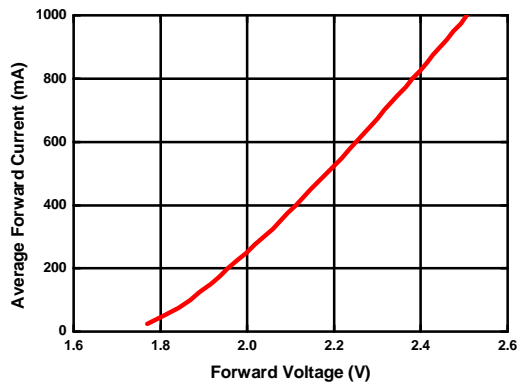

Red

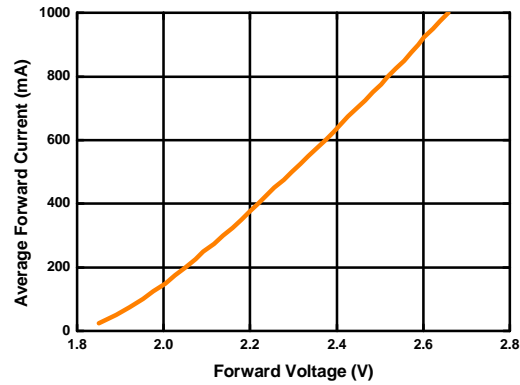

Amber

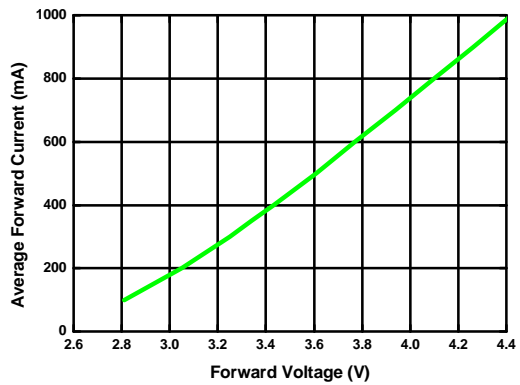

Green

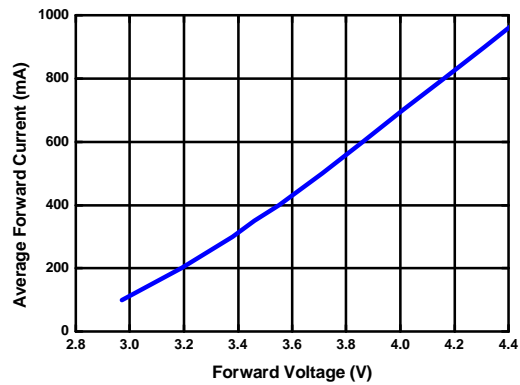

Blue

The information contained herein is the exclusive property of HELIO and shall not be distributed reproduced, or disclosed in whole or in part without prior written permission of HELIO.



HELIO Optoelectronics Corp.

Typical Light Output Characteristics over Forward Current

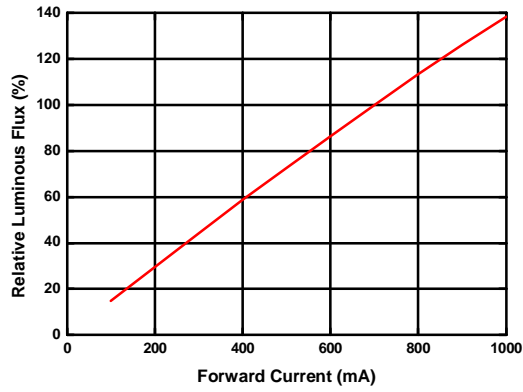

Red

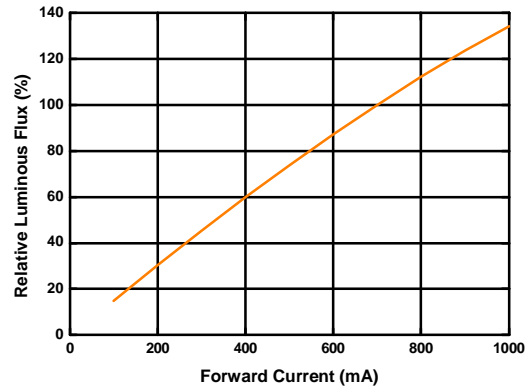

Amber

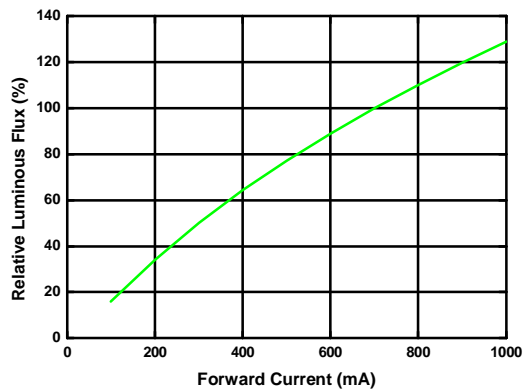

Green

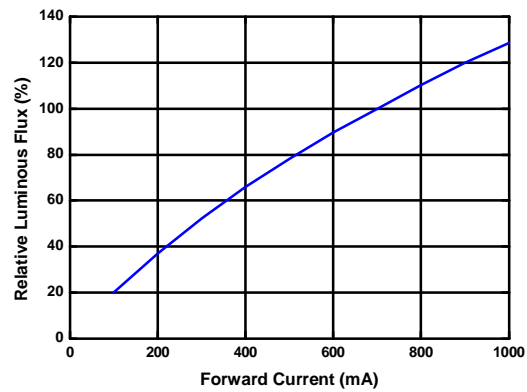

Blue

The information contained herein is the exclusive property of HELIO and shall not be distributed reproduced, or disclosed in whole or in part without prior written permission of HELIO.

HELIO Optoelectronics Corp.

Handling Precaution

The softness and dust affinity of silicone molding lens constrain the handling of LED. Thus, some handling indications of HELIXEON emitters are presented for possible damage prevention and excellent reliability.

- l Avoid leaving fingerprints or scratches (by sharp tools) on the silicone resin parts.
- l Do not force over 2000gf impact or pressure on the silicone molding lens.
- l The LEDs should only be picked up by making contact with the sides of the LED body.
- l When populating in SMT production, the pick-and-place nozzle must not place excessive pressure on the silicone molding lens.

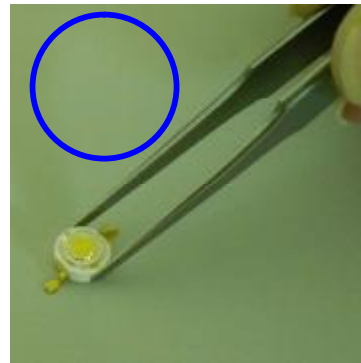



HELIO Optoelectronics Corp.

Reliability Test List

Test Item	Standard Test Method	Test Conditions	Note	Number of Damaged
Resistance to soldering heat (reflow soldering)	JEITA ED-4701 300 301	Ta=260°C, 10sec. (Pre treatment 25°C, 70%, 168hrs.)	2 times	0/10
Solderability (reflow soldering)	JEITA ED-4701 300 303	Tsld=215±5°C, 3sec. (Lead Solder)	1 time over 95%	0/10
Steady state operating life		Ta=25°C, I _F = 700mA Tested with Helio standard circuit board	1000 hrs.	0/10
Steady state operating life of high humidity heat		85°C, RH=85%, I _F = 700mA Tested with Helio standard circuit board	1000 hrs.	0/10
Temperature cycle	JEITA ED-4701 100 105	-40°C ~ 25°C ~ 100°C ~ 25°C 30min. 5min. 30min. 5min.	100 cycles	0/10
Thermal shock	JEITA ED-4701 300 307	0°C ~ 100°C 15sec. 15sec.	20 cycles	0/10
High temperature storage	JEITA ED-4701 200 201	Ta=100°C	1000 hrs.	0/10
Low temperature storage	JEITA ED-4701 200 202	Ta=-40°C	1000 hrs.	0/10
Vibration		2000 Hz, 2directions	60min.	0/10

The information contained herein is the exclusive property of HELIO and shall not be distributed reproduced, or disclosed in whole or in part without prior written permission of HELIO.

HELIO Optoelectronics Corp.

Tube Package Specifications

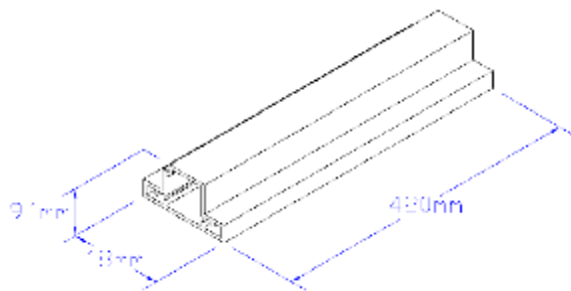

Tube

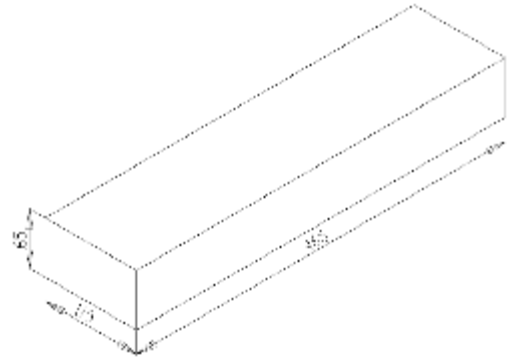

Inner carton

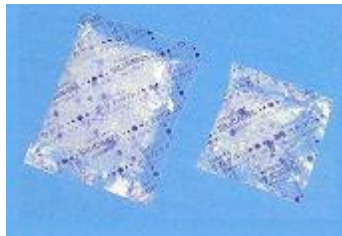

Dry agent

Note:

1. There are 50pcs emitters in a tube.
2. An antistatic bag contains 20 tubes and a drying agent.
3. There are 20 tubes in an inner carton.
4. All dimensions are all in millimeter.

The information contained herein is the exclusive property of HELIO and shall not be distributed reproduced, or disclosed in whole or in part without prior written permission of HELIO.